

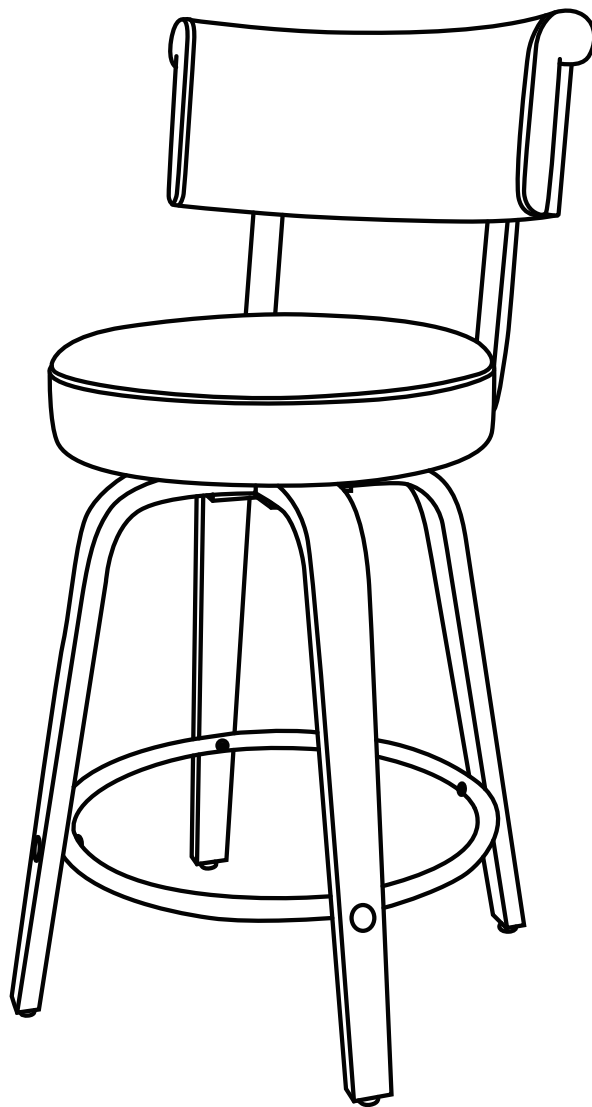

# USER MANUAL



---

**Upholstered Bonded Leather Barstools with Back**

# IMPORTANT NOTICE

Dear customer:

If you receive a product with missing or damaged parts, or if you have any questions about the barstool, please contact Raynesys customer service mailbox for feedback, and we will give you a satisfactory solution.

We are very sorry for the possible inconvenience, and thank you for your understanding and support. Raynesys wishes you a happy life.

You can contact us by following ways:

1. Raynesys customer service mailbox: [support@iRaynesys.com](mailto:support@iRaynesys.com)
2. Contact us on Amazon: From your Amazon order details page, select “Order” >> “Sold by” >> “Contact seller” .

## Attn:

1. Do NOT let your kids climb on the barstool!
2. Prevent children from ingesting anti-mold chip and desiccants in the package!



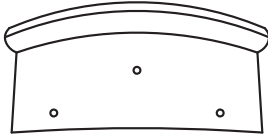
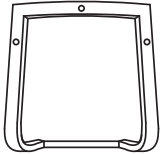
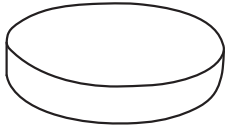
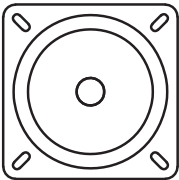
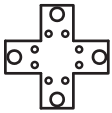
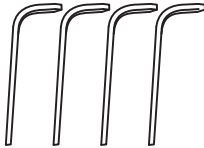
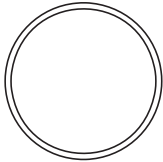

# MAINTENANCE ADVICE

1. Please use a soft cloth or clean damp cloth for cleaning. Do NOT use bleach or abrasive cleaners.
2. Please store in a dry and cool area, avoiding high temperatures and direct sunlight to protect the finish.
3. Do not allow dirt to remain on the surface for a long time.
4. Please use a damp and clean cloth to immediately absorb any spilled liquid.
5. Do NOT lean with products containing the following: acetone (e.g., nail varnish remover), ammonia (e.g.bleach), or sodium hydroxide(e.g., caustic soda, drain, and oven cleaners).
6. Please check whether there are missing screws in the product regularly.
7. The product should NOT be discarded with household waste, and please take it to your local authority waste disposal center.

# PARTS LIST

A(X2) Backrest 		B(X2) Backrest Support Bracket 		C(X2) Seat Cushion 	
D(X2) Metal Connector 	E(X2) Barstool Leg Connector 	F(X8) Barstool Leg 		G(X2) Ring Footrest 	

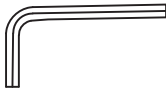
# HARDWARE LIST

H(X24) Screws M6*25 		I(X8) Screws M6*35 		J(X12) Screws M6*35 	
K(X2) Screw Wrench 		L(X8) Adjustable Feet 		M(X8) Decorative Cover 	

# ASSEMBLY STEPS

## ⚠ Please Note:

Please tighten the screws of the barstools for 6 months or irregularly. The installation requires a lot of screws, it is recommended to use an electric drill to install.

### Step 1

Assemble the barstool leg (F) to the barstool leg connector (E) with M6\*25 screw (H).

Note: Tighten the screws to a depth of 70%.

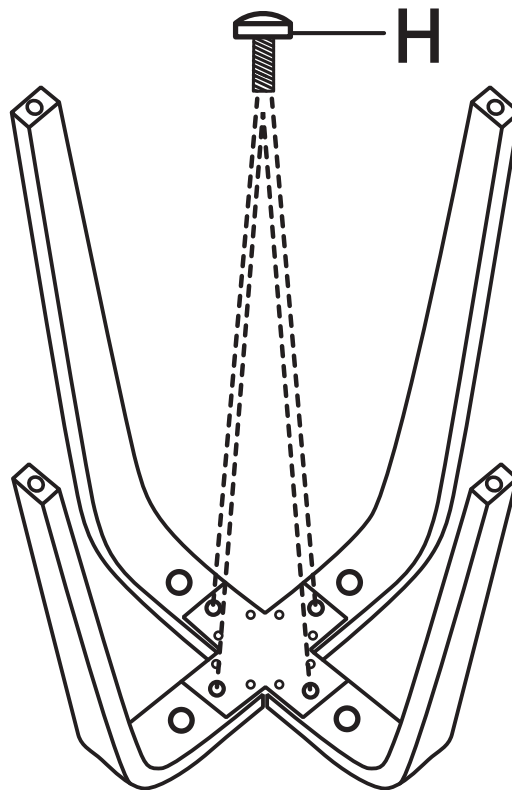

# ASSEMBLY STEPS

## Step 2

Assemble ring footrest (G) to the barstool leg (F) with M6\*35 screw (I).  
Note: Tighten the screws to a depth of 70%.

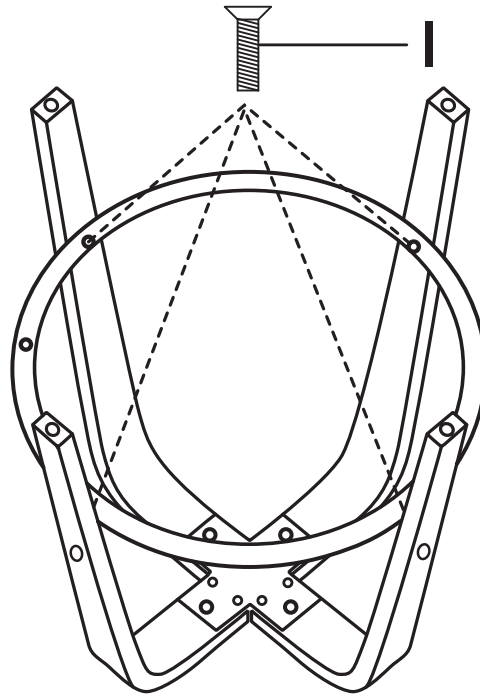

## Step 3

First 45 ° rotate metal connector (D), then assemble metal connector (D) on the top of the barstool legs with M6\*25 screw (H).  
Note: Check and tighten all screws 100%.

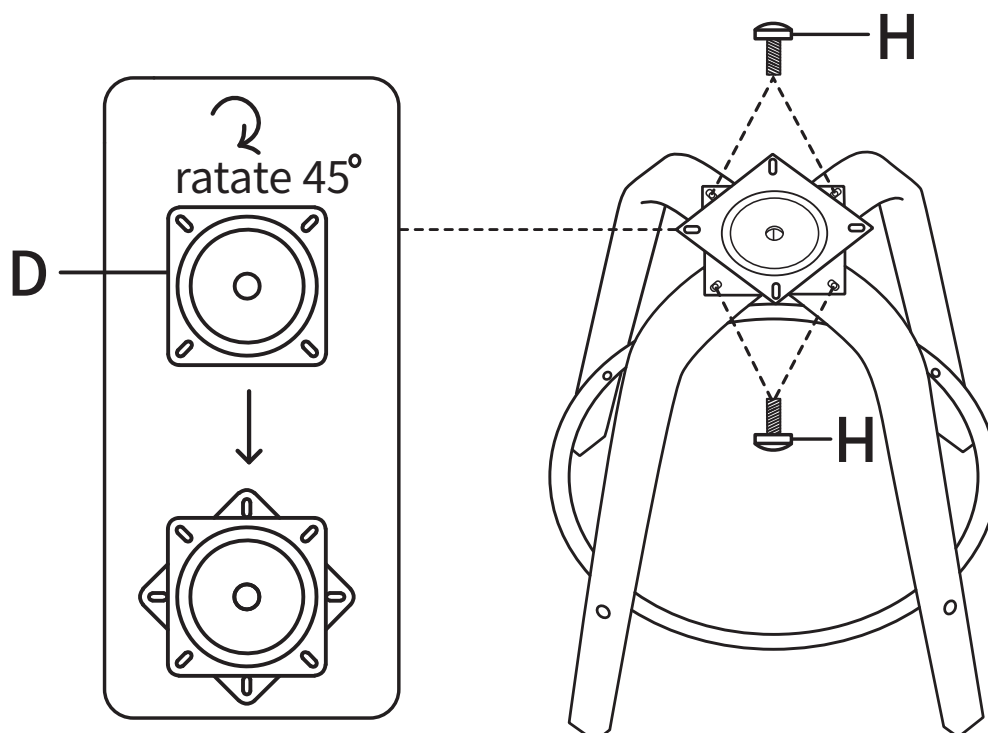

# ASSEMBLY STEPS

## Step 4

Assemble backrest (A) and backrest support bracket (B) with M6\*35 screw (J).

Note: Tighten the screws to a depth of 70%.

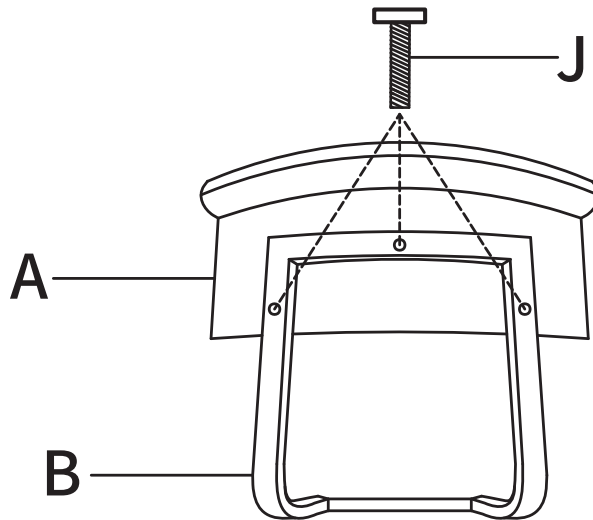

## Step 5

Assemble seat cushion (C) and backrest part with M6\*35 screw (J).

Note: Tighten the screws to a depth of 70%.

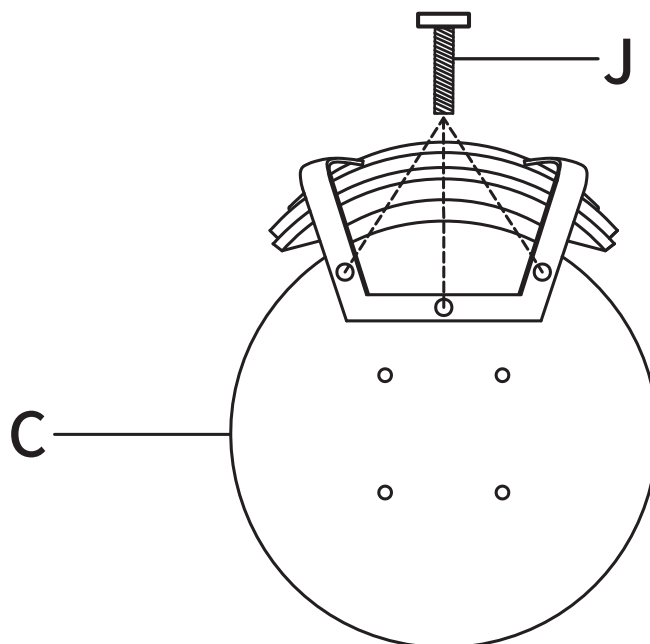

# ASSEMBLY STEPS

## Step 6

Assemble metal connector (D) and seat cushion (C) with M6\*25 screw (H).  
Note: Tighten the screws to a depth of 70%.

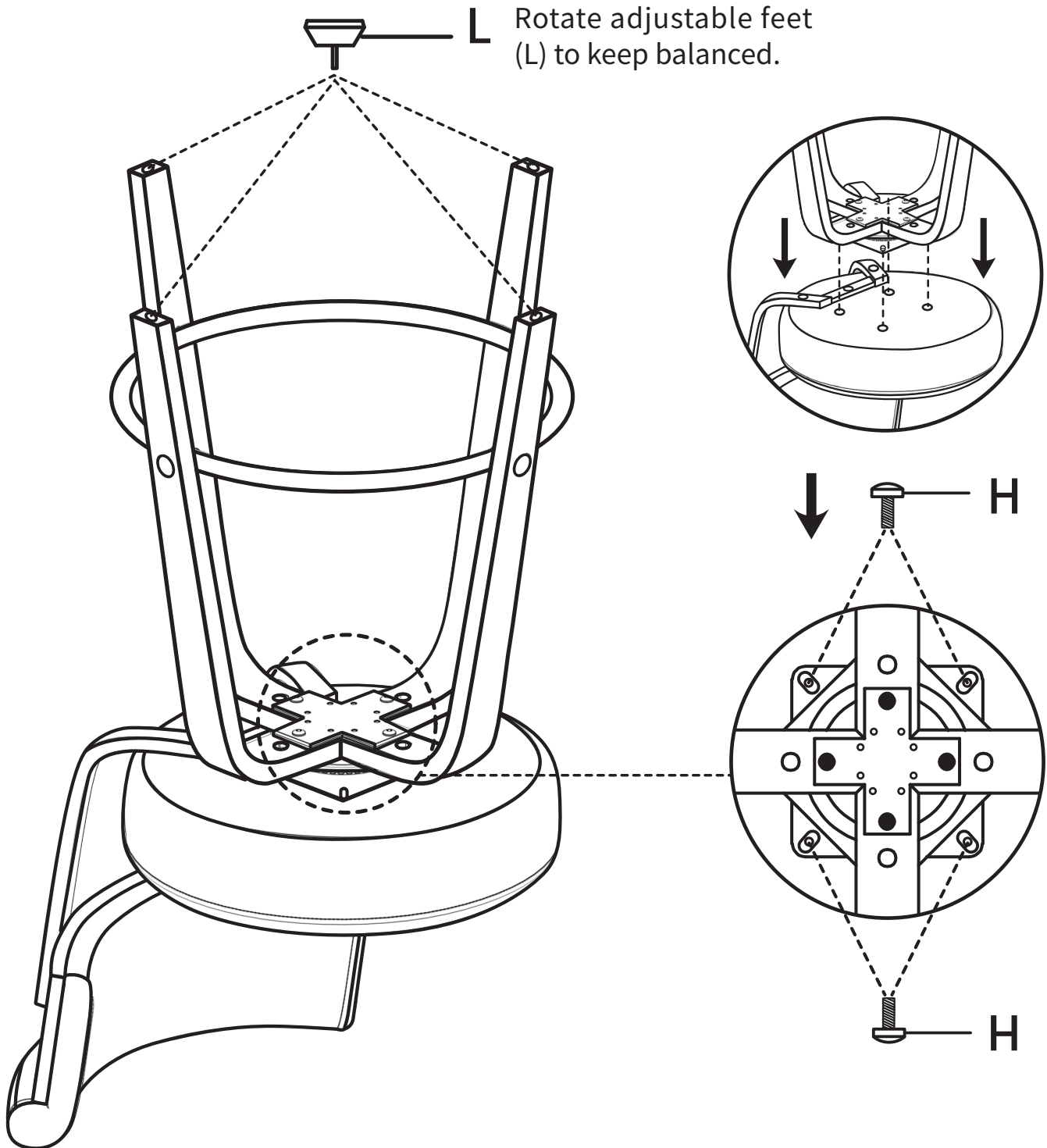

# ASSEMBLY STEPS

## Step 7

Align decorative cover (M) to screw hole, and snap with a gentle pressure.

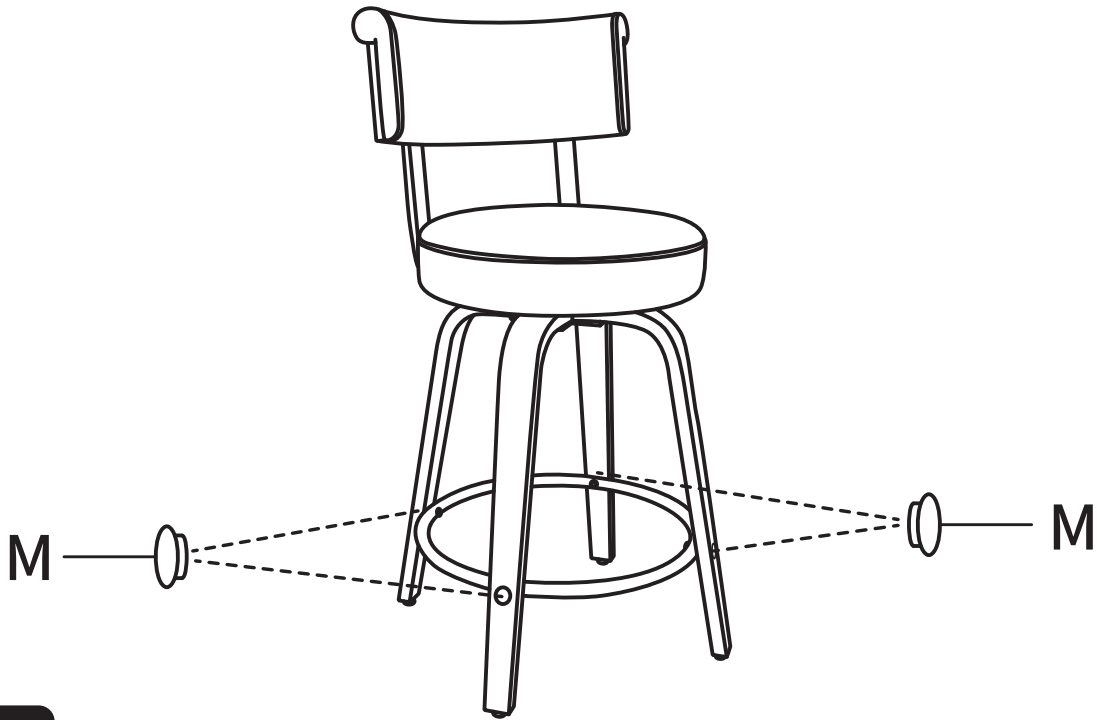

## Step 8

Check whether the barstool is stable and then ready to use.  
Note: Check and tighten all screws 100%.

